



doimo
idea®

doimo
idea®



Diamante

Design: STV

Nasconde un segreto la Consolle Diamante. Con semplici gesti si trasforma da piano di appoggio d'ingresso in tavolo da pranzo. Per pochi ospiti o famiglie numerose, una soluzione per tutte le esigenze.



7D9122 DIAMANTE DA 140 CORDA PORO APERTO - 140 CM CORDA OPEN PORE
7P1122 PICASSO DA 100 CORDA PORO APERTO - 100 CM CORDA OPEN PORE



7D9122 DIAMANTE DA 140 CORDA PORO APERTO - 140 CM CORDA OPEN PORE
7MA149 MAMA BLU TELAIO TUBO QUADRO - BLU SQUARE FRAME TUBE





7D9113 DIAMANTE DA 100 BIANCO LUCIDO - 100 CM GLOSSY BIANCO
7P1123 PICASSO DA 100 BIANCO LUCIDO - 100 CM GLOSSY BIANCO





7D9110 DIAMANTE DA 100 ROVERE MORO - 100 CM DARK OAK
7G6123 GIOTTO DA 70 TESTA DI MORO E MOKA OPACO - 70 CM TESTA DI MORO AND MOKA MATT



Mama

Design: Studio 28

Raffinato colore blu veste di nuovo la sedia Mama. Colore traslucido che traspare nell'ambiente regalando eleganza e unicità. La personalizzazione del telaio: tondo, quadrato, cromato o verniciato, danno il tocco finale.



7MA118 MAMA BLU TUBO TONDO BIANCO - BLU ROUND TUBE BIANCO



7MA149 MAMA BLU TUBO QUADRO - BLU SQUARE TUBE

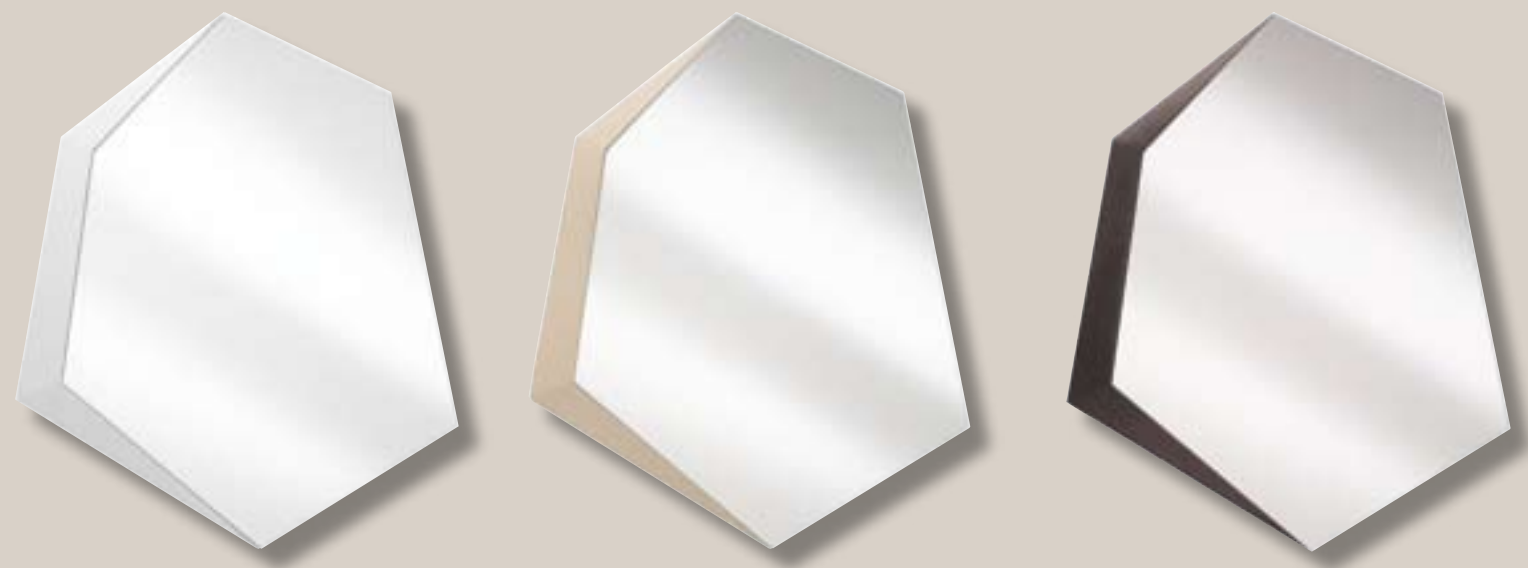

Picasso

Design: Studio Evolution

Lo specchio Picasso si presenta con forma esagonale, irregolare, ma non spigolosa. Personalizzabile tramite il colore della cornice che si allarga su di un solo lato. In essenza o laccato, di grande o piccola misura, proposto da solo o in composizione di più pezzi, Picasso regala ad ogni ambiente la soluzione ottimale.



7P1112 PICASSO DA 60 CORDA PORO APERTO - 60 CM CORDA OPEN PORE
7P1122 PICASSO DA 100 CORDA PORO APERTO - 100 CM CORDA OPEN PORE





7G6113 GIOTTO DA 45 CARAMELLO E CARAMELLO OPACO - 45 CM CARAMELLO E CARAMELLO MATT
7G6123 GIOTTO DA 70 CARAMELLO E CARAMELLO OPACO - 70 CM CARAMELLO E CARAMELLO MATT



Giotto

Design: Studio Evolution

Lo specchio Giotto si ispira apertamente al più famoso tra i cerchi della storia dell'arte. Pennellate semplici e dettagliate trasformano la cornice in cuoietto che lo cingono in un oggetto indimenticabile.



Giotto

Un particolare unico dettaglia lo specchio Giotto: la fibbia in metallo posta a lato strizza gli occhi agli anni '50.







Hellen

Design: EPI Studio

Intrecci innovativi quelli utilizzati per rivestire la sedia Hellen. Il materiale utilizzato deriva dalla fibra di legno e possiede eccezionali caratteristiche tecniche di punibilità e antibattericità.



7H7123 HELLEN MOKA OPACO INTRECCIO COCCO - MOKA MATT WOVEN COCCO





7H7123 HELLEN GRIGIO OPACO INTRECCIO CICLAMINO - GRIGIO MATT WOVEN CICLAMINO



7H7123 HELLEN NERO OPACO INTRECCIO ROSSO - NERO MATT WOVEN ROSSO



7H7123 HELLEN BIANCO OPACO INTRECCIO ICE - BIANCO MATT WOVEN ICE



73A122 AIDA TUBO TONDO BIANCO INTRECCIO ICE - ROUND TUBE BIANCO WOVEN ICE



Aida

Design: Studio Evolution

Semplice, sobria ed essenziale, la sedia Aida è un "must" con certamente non può mancare. Il rivestimento a intreccio, la rende frizzante e innovativa.



73A132 AIDA TUBO QUADRO INTRECCIO CICLAMINO - SQUARE TUBE WOVEN CICLAMINO



73A122 AIDA TUBO TONDO CROMO INTRECCIO NERO - ROUND TUBE CHROMED WOVEN NERO



Nancy

Design: EPI Studio

Schienale alto e accogliente, forma semplice e rassicurante: Nancy è la sedia pensata per unire comodità a eleganza e pulizia delle forme.





7NA122 NANCY INTRECCIO ICE - *WOVEN ICE*



Madame

Design: Studio Evolution

Elegante e ricercata: è la console Madame. Le morbide curve delle sue gambe nascondono le allunghe, utilizzate per trasformarla in tavolo di grandi dimensioni.



7M6124 MADAME DA 140 CORDA PORO APERTO - 140 CM CORDA OPEN PORE
76D102 DONATELLO DA 150 CM



7M6124 MADAME DA 140 CORDA PORO APERTO - 140 CM CORDA OPEN POOR
7A4113 ANTEA BIANCO LUCIDO PELLE 1235 TRAPUNTATA - BIANCO GLOSSY LEATHER 1235 QUILTED



7M6113 MADAME DA 100 BIANCO OPACO - 100 CM BIANCO MATT
76D101 DONATELLO DA 105 CM





7M6110 MADAME DA 100 ROVERE MORO E CROMO - 100 CM DARK OAK AND CHROMED
7A4112 ANTEA BIANCO LUCIDO PELLE 1301 TRAPUNTATA - BIANCO GLOSSY LEATHER 1301 QUILTED





Donatello

Design: Studio Evolution

Fili in vetro di Murano, morbidamente adagiati sullo specchio Donatello, creano una cornice accogliente e rinascimentale. Il colore argento crea riflessi e bagliori indimenticabili.





76D102 DONATELLO DA 150 CM



76D101 DONATELLO DA 105 CM



76D103 DONATELLO DA 195 CM



Antea

Design: Roberto Pravato

Quando si pensa ad una sedia classica, non può mancare Antea. Rigorosa nelle forme e perfetta nella cura della lavorazione e nei dettagli. La sua lavorazione nasce dalla maestria di sapienti mani artigiane.



7A4113 ANTEA BIANCO LUCIDO PELLE 1235 TRAPUNTATA - BIANCO GLOSSY LEATHER 1235 QUILTED



7A4113 ANTEA BIANCO LUCIDO PELLE 1235 TRAPUNTATA - BIANCO GLOSSY LEATHER 1235 QUILTED
7P6121 POSILLIPO BIANCO LUCIDO PIANO VETRO EXTRACHIARO BIANCO - BIANCO GLOSSY GLASS TOP EXTRA-CLEAR BIANCO



7A4113 ANTEA BIANCO LUCIDO PELLE 1235 TRAPUNTATA - BIANCO GLOSSY LEATHER 1235 QUILTED

Posillipo Carrara

Design: Studio 28

La pietra per eccellenza: il marmo di Carrara, rende il tavolo Posillipo un pezzo unico e irrinunciabile per chi vuole una casa di massima eleganza e sofisticata raffinatezza.



7A4112 ANTEA BIANCO LUCIDO PELLE 1301 TRAPUNTATA - BIANCO GLOSSY LEATHER 1301 QUILTED



7P6123 POSILLIPO BIANCO LUCIDO PIANO MARMO DI CARRARA - BIANCO GLOSSY CARRARA MARBLE TOP

Posillipo

Design: Studio 28



7P6123 POSILLIPO BIANCO LUCIDO PIANO MARMO DI CARRARA - BIANCO GLOSSY CARRARA MARBLE TOP
7A4112 ANTEA BIANCO LUCIDO PELLE 1301 TRAPUNTATA - BIANCO GLOSSY LEATHER 1301 QUILTED



7P6121 POSILLIPO NERO LUCIDO PIANO VETRO NERO - NERO GLOSSY GLASS TOP NERO
7A4112 ANTEA NERO LUCIDO PELLE 1293 TRAPUNTATA - NERO GLOSSY LEATHER 1293 QUILTED



7A4114 ANTEA BIANCO LUCIDO MATRIX 1080 - BIANCO GLOSSY MATRIX 1080



Descrizioni tecniche *Technical data*



Diamante

Design: STV



Descrizione articolo

Consolle allungabile in legno o laccata

Finitura gambe

Laccato opaco poro aperto come campionario
Laccato lucido come campionario
Laccato opaco come campionario
Rovere moro

Item description

Wood or lacquered extensible console

Legs Finishes

Lacquered open pore as per samples collection
Glossy lacquered as per samples collection
Matt lacquered as per samples collection
Dark oak

Beschreibung des Artikels

Ausziehbarer Konsolentisch in Holz oder Lack

Ausführung der Beine

Lack Matt offenporig nach Musterauswahl
Lack Hochglanz nach Musterauswahl
Lack Matt nach Musterauswahl
Eiche Dunkelbraun

Description article

Consolle allongeable en bois ou laquée

Finition pieds

Laqué opaque pore ouvert comme échantillon
Laqué brillant comme échantillon
Laqué opaque comme échantillon
Chêne rouvre foncé

Descricion articulo

Consola extensible en madera o lacada

Acabados patas

Madera lacada a poro abierto como muestrario
Lacado brillo como muestrario
Lacado mate como muestrario
Roble oscuro

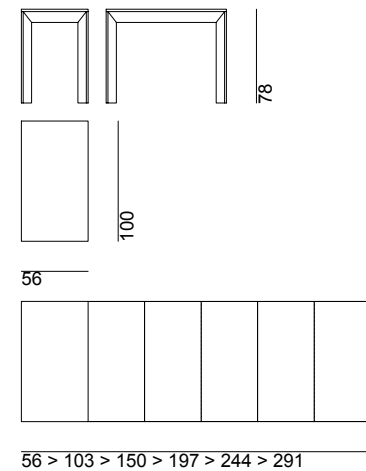

56 > 103 > 150 > 197 > 244 > 291

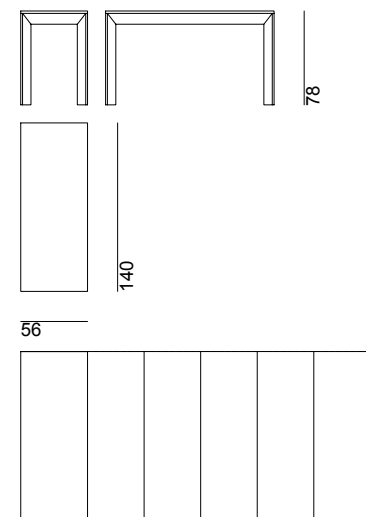

56 > 103 > 150 > 197 > 244 > 291

Madame

Design: Studio Evolution



Descrizione articolo

Consolle allungabile impiallacciata o laccata con gambe in metallo

Finitura gambe

Cromato
Laccato opaco come campionario
Finitura struttura
Laccato opaco poro aperto come campionario
Laccato opaco come campionario
Rovere moro

Item Description

Extensible console wood veneered or lacquered with metal legs

Legs finishes

Chromed
Matt wood lacquered as per samples collection
Structure finishes
Matt wood lacquered as per samples collection
Matt lacquered as per samples collection
Dark oak

Beschreibung des Artikels

Ausziehbarer Konsolentisch in Furnier oder Lack mit Beinen aus Metall

Ausführung der Beine

Verchromt
Lack Matt nach Musterauswahl

Ausführung des Korpus

Lack Matt offenporig nach Musterauswahl
Lack Matt nach Musterauswahl
Eiche Dunkelbraun

Description article

Consolle allongeable plaquée ou laquée avec pieds en métal

Finition pieds

Chromé
Laqué opaque comme échantillon

Finition structure

Laqué opaque pore ouvert comme échantillon
Laqué opaque comme échantillon
Chêne rouvre foncé

Descricion articulo

Consola extensible en madera chapada o lacada con patas de metal

Acabados patas

Cromado
Lacado mate como muestrario

Acabado estructura

Madera lacada a poro abierto como muestrario
Lacado mate como muestrario
Roble oscuro

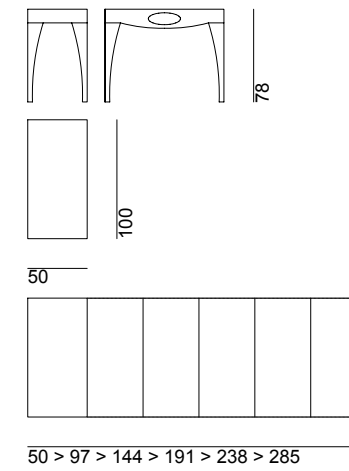

50 > 97 > 144 > 191 > 238 > 285

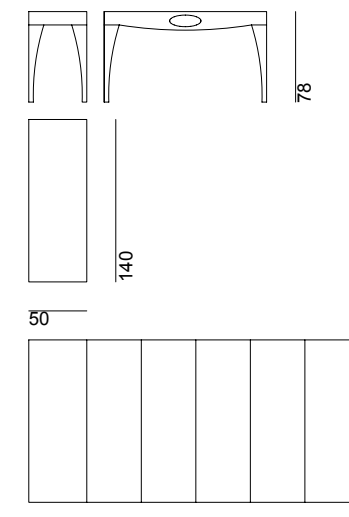

50 > 97 > 144 > 191 > 238 > 285

Mama

Design: Studio 28



Descrizione articolo

Sedia con gambe in metallo a sezione quadra o tonda. Monoscocca in policarbonato

Finitura gambe o telaio

Sezione quadra: cromato

Sezione tonda: cromato, verniciato bianco, verniciato nero, verniciato alluminio

Finitura scocca

Policarbonato blu

Item description

Chair with square or round metal legs. Single shell in polycarbonate finish

Legs or frame finishes

Square section: chromed

Round section: chromed, varnished bianco, varnished nero, varnished alluminio

Structure finish

Polycarbonate blu

Beschreibung des Artikels

Stuhl mit viereckigen oder runden Beinen in Metall. Sitzschale in Polycarbonat

Ausführung der Beine oder des Gestells

Viereckige Beine: verchromt

Runde Beine: verchromt, Lack Weiß, Lack Schwarz, Lack Aluminium

Ausführung der Sitzschale

Blaues Polycarbonat

Description article

Chaise avec pieds en métal à section carrée ou ronde. Monocoque en polycarbonate

Finition pieds ou cadre

Section carrée: chromé

Section ronde: chromé, verni blanc, verni noir, verni aluminium

Finition coque

Polycarbonate bleu

Descripcion articulo

Silla con patas de metal con asiento en policarbonato

Acabados patas o marco

Sección cuadradas: cromado

Sección redonda: cromado, barnizado blanco, barnizado negro, barnizado aluminio

Acabado estructura

Policarbonato blu

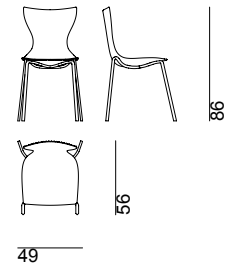
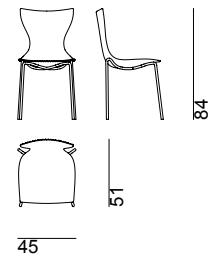

Nancy

Design: EPI Studio



Descrizione articolo

Sedia con struttura in metallo rivestita in fibra naturale di legno intrecciato

Finiture gambe o telaio

Cromato

Finiture rivestimento

Intrecciato come campionario

Item description

Chair with metal structure natural wood texture woven covered

Legs or frame finish

Chromed

Covered finish

Woven as per samples collection

Beschreibung des Artikels

Stuhl mit Gestell in Metall bezogen mit Naturfaser in Holzgeflecht

Ausführung der Beine oder des Gestells

Verchromt

Ausführung des Bezugs

Geflecht nach Musterauswahl

Description article

Chaise avec structure en métal revêtue en fibre naturel en bois intressé

Finition pieds ou cadre

Chromé

Finition revêtement

Intressé comme échantillon

Descripcion articulo

Silla con estructura de metal revestida en fibra de madera natural trenzada

Acabado patas o marco

Cromado

Acabado revestimiento

Trenzado como muestrario

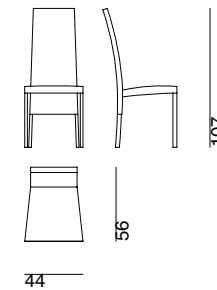

Hellen

Design: EPI Studio



Descrizione articolo

Sedia con gambe in legno e monoscocca rivestita in fibra naturale di legno intrecciato

Finiture gambe o telaio

Laccato lucido come campionario

Laccato opaco come campionario

Rovere moro

Finiture rivestimento

Intrecciato come campionario

Item description

Chair with wood legs and single shell covered by natural woven wood texture

Legs or frame finishes

Glossy lacquered as per samples collection

Matt lacquered as per samples collection

Rovere moro

Covered finish

Woven as per samples collection

Beschreibung des Artikels

Stuhl mit Beinen in Holz und Sitzschale bezogen mit Naturfaser in Holzgeflecht

Ausführung der Beine oder des Gestells

Lack Hochglanz nach Musterauswahl

Lack Matt nach Musterauswahl

Eiche Dunkelbraun

Ausführung des Bezugs

Geflecht nach Musterauswahl

Description article

Chaise avec pieds en bois et monocoque revêtue en fibre naturel en bois intressé

Finition pieds ou cadre

Laqué brillant comme échantillon

Laqué opaque comme échantillon

Chêne rouvre foncé

Finition revêtement

Intressé comme échantillon

Descripcion articulo

Silla con patas en madera y asiento revestido en fibra de madera natural trenzada.

Acabados patas o marco

lacado brillo como muestrario

lacado mate como muestrario

Roble oscuro

Acabado revestimiento

Trenzado como muestrario

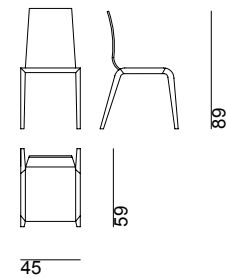

Aida

Design: Studio Evolution



Descrizione articolo

Sedia con gamba in metallo a sezione quadra o tonda . Monoscocca in multistrato rivestito in fibra naturale di legno intrecciato

Finiture gambe o telaio

Sezione quadra: cromato

Sezione tonda: cromato, verniciato bianco, verniciato nero, verniciato alluminio

Finiture rivestimento

Intrecciato come campionario

Item description

Chair with square or round metal legs. Single shell plywood texture covered

Legs or frame finishes

Square section: chromed

Round section: chromed, varnished bianco, varnished nero, varnished alluminio

Covered finish

Woven as per samples collection

Beschreibung des Artikels

Stuhl mit viereckigen oder runden Beinen in Metall. Sitzschale in Schichtholz mit Naturfaser in Holzgeflecht

Ausführung der Beine oder des Gestells

Viereckige Beine: verchromt

Runde Beine: verchromt, Lack Weiß, Lack Schwarz, Lack Aluminium

Ausführung des Bezugs

Geflecht nach Musterauswahl

Description article

Chaise avec pied en métal à section carré ou ronde. Monocoque en multiplis revêtu en fibre naturel en bois intressé

Finition pieds ou cadre

Section carré: chromé

Section ronde: chromé, verni blanc, verni noir, verni aluminium

Finition revêtement

Intressé comme échantillon

Descripcion articulo

Silla con patas de metal a seccion cuadrada o redonda con asiento de multistrato revestido en fibra

Acabados patas o marco

Sección cuadradas: cromado

Sección redonda: cromado, barnizado blanco, barnizado negro, barnizado aluminio

Acabado revestimiento

Trenzado como muestrario

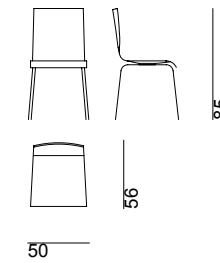

Antea

Design: Roberto Pravato



Descrizione articolo

Sedia in legno imbottita in tessuto o pelle. Non sfoderabile

Finiture gambe o telaio

Laccato lucido come campionario

Laccato opaco come campionario

Finiture rivestimento

Tessuto o pelle come campionario

Item description

Fabric or leather upholstered wood chair. Not removable cover

Legs or frame finishes

Glossy lacquered as per samples collection

Matt lacquered as per samples collection

Covered finish

Fabric or leather as per samples collection

Beschreibung des Artikels

Stuhl in Holz gepolstert mit Stoff oder Leder. Nicht abziehbar

Ausführung der Beine oder des Gestells

Lack Hochglanz nach Musterauswahl

Lack Matt nach Musterauswahl

Ausführung des Bezugs

Stoff oder Leder nach Musterauswahl

Description article

Chaise en bois rembourrée en tissu ou cuir. Non déhoussable

Finition pieds ou cadre

Laqué brillant comme échantillon

Laqué opaque comme échantillon

Finition revêtement

Tissu ou cuir comme échantillon

Descricion articulo

Silla de madera tapizada en tejido o piel. No desenfundable

Acabado patas o marco

Lacado brillo como muestrario

Lacado mate como muestrario

Acabado revestimiento

Tejido o piel como muestrario

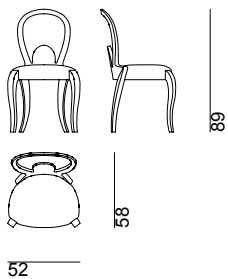

Posillipo

Design: Studio 28



Descrizione articolo

Tavolo con base in metallo e legno. Piano in vetro laccato

Finiture gambe o telaio

Laccato lucido come campionario

Laccato opaco come campionario

Finitura piano

Vetro laccato: bianco mare, nero

Vetro extrachiaro bianco

Item description

Table with metal and wood base. Lacquered glass top

Legs or frame finishes

Glossy lacquered as per samples collection

Matt lacquered as per samples collection

Top finishes

Lacquered glass : bianco mare, nero

Extra-clear glass bianco

Beschreibung des Artikels

Tisch mit Gestell in Metall und Holz. Tischplatte in lackiertem Glas

Ausführung der Beine oder des Gestells

Lack Hochglanz nach Musterauswahl

Lack Matt nach Musterauswahl

Ausführung der Tischplatte

Lackiertes Glas: Meerweiß, Schwarz

Extrahelles Glas Weiß

Description article

Table avec base en métal et bois. Plan en verre laqué

Finition pieds ou cadre

Laqué brillant comme échantillon

Laqué opaque comme échantillon

Finition plan

Verre laqué: blanc mer, noir

Verre extra-clair blanc

Descricion articulo

Mesa con base de metal y madera. Tapa de cristal lacado

Acabados patas o marco

lacado brillo como muestrario

lacado mate como muestrario

Acabado tapas

Cristal lacado : bianco mare, nero

Cristal extra-claro Bianco

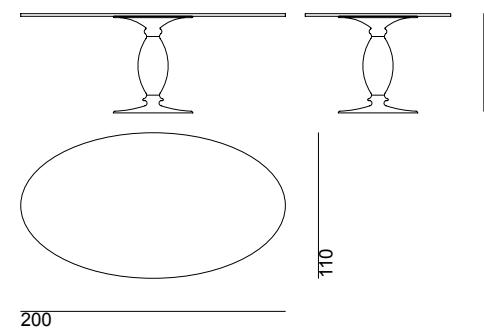
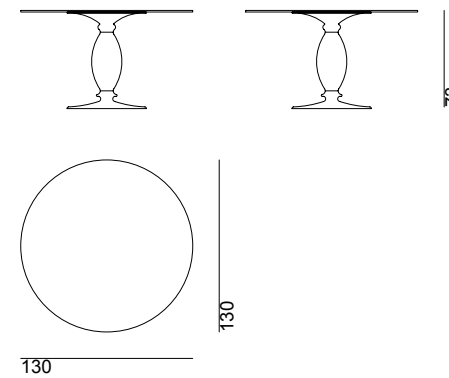

Posillipo Carrara

Design: Studio 28



Descrizione articolo

Tavolo con base in metallo e legno. Piano in marmo di Carrara

Finiture gambe o telaio

Laccato lucido come campionario

Laccato opaco come campionario

Finitura piano

Marmo di Carrara

Item description

Table with metal and wood base. Carrara marble top

Legs or frame finishes

Glossy lacquered as per samples collection

Matt lacquered as per samples collection

Top finish

Carrara marble top

Beschreibung des Artikels

Tisch mit Gestell in Metall und Holz. Tischplatte in Carrara-Marmor

Ausführung der Beine oder des Gestells

Lack Hochglanz nach Musterauswahl

Lack Matt nach Musterauswahl

Ausführung der Tischplatte

Carrara-Marmor

Description article

Table avec base en métal et bois. Plan en marbre de Carrara

Finition pieds ou cadre

Laqué brillant comme échantillon

Laqué opaque comme échantillon

Finition plan

Marbre de Carrara

Descripcion Articulo

Mesa con base de madera y metal. Tapa de marmol de carrara

Acabados patas o marco

lacado brillo como muestrario

lacado mate como muestrario

Acabado tapa

Marmol de carrara

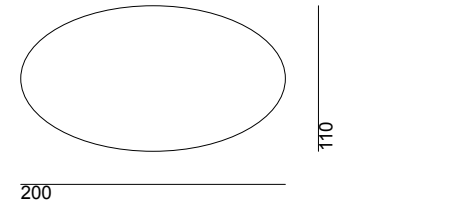
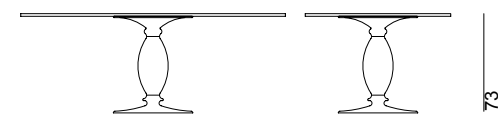
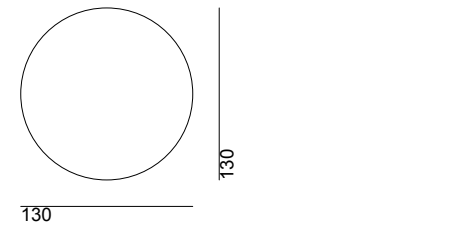

Donatello

Design: Studio Evolution



Descrizione articolo

Specchiera da parete con cornice in filo di vetro

Finitura cornice

Argento lucido

Item description

Wall mirror with wire glass frame

Frame finish

Glossy silver

Beschreibung des Artikels

Wandspiegel mit Rahmen in Glasfaden

Ausführung des Rahmens

Silber Hochglanz

Description article

Miroir paroi avec corniche en fil de verre

Finition cornice

Argent brillant

Descripcion articulo

Espejo para pared con marco en hilo de cristal

Acabado marco

Plata brillante

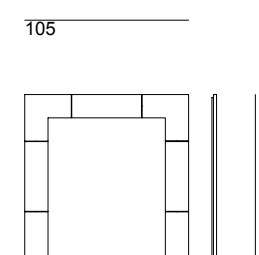
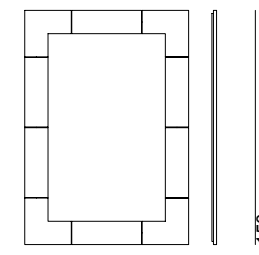
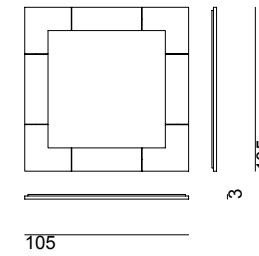

Picasso

Design: Studio Evolution



Descrizione articolo

Specchiera da parete con cornice in legno

Finitura cornice

Laccato opaco poro aperto come campionario

Laccato lucido come campionario

Laccato opaco come campionario

Rovere moro

Item description

Wall mirror with wood frame

Frame finishes

Matt wood lacquered open pore as per our samples colours

Glossy lacquered as per samples collection

Matt lacquered as per samples collection

Rovere moro

Beschreibung des Artikels

Wandspiegel mit Rahmen in Holz

Ausführung des Rahmens

Lack Matt offenporig nach Musterauswahl

Lack Hochglanz nach Musterauswahl

Lack Matt nach Musterauswahl

Eiche Dunkelbraun

Description article

Miroir paroi avec corniche en bois

Finition corniche

Laqué opaque pore ouvert comme échantillon

Laqué brillant comme échantillon

Laqué opaque comme échantillon

Chêne rouvre foncé

Descripcion articulo

Espejo para pared con marco de madera

Acabados marco

Madera lacada a poro abierto como muestrario

Lacado brillo como muestrario

Lacado mate como muestrario

Roble oscuro

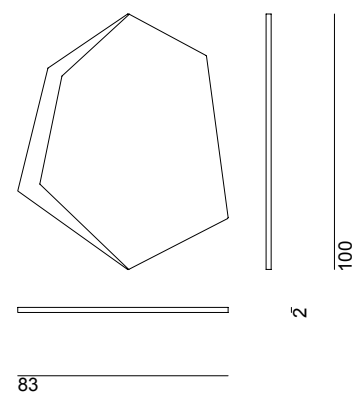
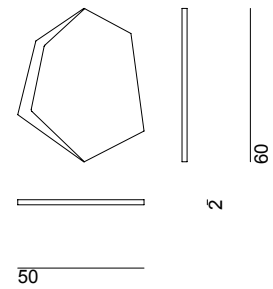

Giotto

Design: Studio Evolution



Descrizione articolo

Specchiera da parete con cornice laccata e cinghia in cuoietto

Finitura cornice

Laccato opaco come campionario

Finitura cinghia

Cuoietto come campionario

Item description

Wall mirror with lacquered frame and hard-leather belt

Frame finish

Matt lacquered as per our samples collection

Belt finish

Hard-leather as per our samples collection

Beschreibung des Artikels

Wandspiegel mit Rahmen in Lack und Riemen in Kunstleder

Ausführung des Rahmens

Lack Matt nach Musterauswahl

Ausführung des Riemens

Kunstleder nach Musterauswahl

Description article

Miroir paroi avec corniche laquée et courroie en cuir "cuoietto"

Finition corniche

Laqué opaque comme échantillon

Finition courroie

Cuir "cuoietto" comme échantillon

Descripcion articulo

Espejo para pared con marco lacado y cinturón de cuero

Acabado marco

Madera lacada a poro abierto como muestrario

Acabado cinturón

Cuero como muestrario

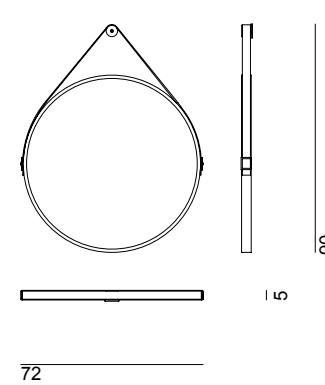
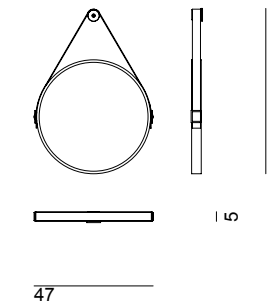



Ringraziamenti *Special thanks to:*



DOIMO IDEA srl
Via Montegrappa, 90
31010 Mosnigo di Moriago (TV) - Italy
Tel. +39 0438 890577 - Fax +39 0438 890539
info@doimoidea.it - www.doimoidea.it

